

1867 Megohmmeter Instruction Manual

Form 150355/A3

©QuadTech, Inc., 2000
5 Clock Tower Place, 210 East
Maynard, Massachusetts, U.S.A. 01754
December 2002

Telephone	978-461-2100
Sales	800-253-1230
Facsimile	978-461-4295
Website	www.quadtech.com

The material in this manual is for informational purposes only and is subject to change, without notice. QuadTech assumes no responsibility for any error or for consequential damages that may result from the misinterpretation of any procedures in this publication.

WARNING

Potentially dangerous voltages may be present on front and rear panel terminals. Follow all warnings in this manual when operating or servicing this instrument. Dangerous levels of energy may be stored in capacitive devices tested by this unit.
Always make sure the High Voltage indicator is **OFF** when connecting or disconnecting the device under test.



Product will be marked with this symbol (ISO#3864) when it is necessary for the user to refer to the instruction manual in order to prevent injury or equipment damage.



Product marked with this symbol (IEC417) indicates presence of direct current.



Product will be marked with this symbol (ISO#3864) when voltages in excess of 1000V are present.

Contents

Warranty	5
Specifications	7
Accessories	9
Safety Precautions	11
Condensed Operating Instructions	13
Introduction - Section 1	
1.1	Unpacking and Inspection 15
1.2	Product Overview 15
1.3	Controls and Indicators..... 16
1.3.1	Front Panel Controls and Indicators 16
1.3.2	Rear Panel Controls and Connectors 18
1.4	Installation 19
1.4.1	Dimensions 19
1.4.2	Instrument Positioning..... 19
1.4.3	Power Requirements..... 19
1.4.4	Safety Inspection 21
Operation - Section 2	
2.1	Terms and Conventions 23
2.2	Startup 25
2.3	Zeroing 25
2.4	Setting Limits 26
2.5	D-C-M Toggle Switch 26
2.6	Resistance Ranges 26
2.7	Voltage Selector 27
2.8	Test Voltage..... 27
2.9	Buzzer DIP Switch 27
2.10	Connection to Device Under Test 28
2.10.1	Two-wire UNGROUNDED 29
2.10.2	Two-wire GROUNDED 30
2.10.3	Three-wire GUARDED 31
2.11	Measurement Procedure 32
2.11.1	Manual Measurement Mode..... 32
2.12	Remote I/O..... 33

Contents (Continued)

Applications - Section 3

3.1	Insulation Resistance Testing	35
3.2	Test Sample Resistivity Measurements.....	36
3.3	Capacitor Insulation Resistance	37
	3.3.1 Charge Time Constant	38
	3.3.2 Discharge Time.....	38
3.4	Resistance Measurements.....	39
3.5	Measurement of Voltage Coefficient	39
3.6	Guarded, 3-Terminal Measurements	40

Service & Calibration - Section 4

4.1	General.....	41
4.2	Instrument Return	41
4.3	Calibration	41
	4.3.1 Calibration Equipment.....	41
	4.3.2 Calibration Procedure	42
	4.3.2.1 Output Voltage Adjustment	42
	4.3.2.2 Offset Voltage Adjustment	42
	4.3.2.2 Accuracy Adjustment	42

Warranty



QuadTech warrants that Products are free from defects in material and workmanship and, when properly used, will perform in accordance with QuadTech's applicable published specifications. If within one (1) year after original shipment it is found not to meet this standard, it will be repaired, or at the option of QuadTech, replaced at no charge when returned to a QuadTech service facility.

Changes in the Product not approved by QuadTech shall void this warranty.

QuadTech shall not be liable for any indirect, special or consequential damages, even if notice has been given of the possibility of such damages.

This warranty is in lieu of all other warranties, expressed or implied, including, but not limited to any implied warranty or merchantability or fitness for a particular purpose.

SERVICE POLICY

QuadTech's service policy is to maintain product repair capability for a period of at least five (5) years after original shipment and to make this capability available at the then prevailing schedule of charges.

Accessories

Accessories Included

Item	Quantity	QuadTech P/N
AC Power Cord	1	4200-0300
Red HV Test Cable	1	1867-01
Black Ground Cable	1	
Fuse 0.315A 250V: 115V Operation	1	520075
Instruction Manual	1	150355
Calibration Certificate	1	N/A

Accessories/Options Available

The 1867 Megohmmeter instrument comes standard with necessary accessories. The instrument does not require any optional accessories.

Safety Precautions

The 1867 Megohmmeter can provide an output voltage as high as 1090V to the external device under test (DUT). Although the 1867 unit is designed with full attention to operator safety, serious hazards could occur if the instrument is used improperly and these safety instructions are not followed.

1. The 1867 unit is designed to be operated with its chassis connected to earth ground. The 1867 instrument is shipped with a three-prong power cord to provide this connection to ground. This power cord should only be plugged in to a receptacle that provides earth ground. Serious injury can result if the instrument is not connected to earth ground.
2. Tightly connect cable(s) to the yellow **GND** terminal. If this is not done, the DUT's casing can be charged to the high voltage test level and serious injury or electrical shock hazards could result if the DUT is touched.
3. Never touch the metal of the High Voltage probe directly. Touch only the insulated parts of the lead(s).
4. Never touch the test leads, test fixture or DUT in any manner (this includes insulation on all wires and clips) when the high voltage is applied and the **Caution High Voltage** LED is ON.
5. Before turning on the 1867 unit, make sure the D-C-M toggle is in the **DISCHARGE** position and that there is no device (DUT) or fixture attached to the test leads.
6. After each test, switch the D-C-M toggle switch to **DISCHARGE** for safety.
7. When the **Caution High Voltage** LED is lit **NEVER** touch the device under test, the lead wires or the output terminals.
8. Before touching the test lead wires or output terminals make sure :
 - a) **The Caution High Voltage** LED is OFF.
 - b) The D-C-M toggle switch is switched to **DISCHARGE** and the DUT has had time to discharge.
9. **In the case of an emergency**, turn OFF the [POWER] switch using a “hot stick” and disconnect the AC power cord from the wall. **DO NOT TOUCH THE 1867 INSTRUMENT.**
10. If the **Caution High Voltage** LED does not go **off** when the D-C-M toggle switch is switched to DISCHARGE, immediately stop using the tester. It is possible that the output voltage is still being delivered regardless of the TEST ON/OFF control signal.

Condensed Operating Instructions

WARNING

High Voltage is applied to the measurement terminals of the 1867 anytime the **Caution High Voltage** LED is **ON**. While the current from the instrument is limited, the energy stored in a capacitive device connected to the terminals may be lethal. Always make sure the **Caution High Voltage** LED is **OFF** when connecting or disconnecting the unknown.

General Information

The 1867 Megohmmeter/IR Tester is a measuring instrument for direct readout of resistance. The voltage applied to the device under test (DUT) is adjustable from 1 to 1090 volts. An L.NG, GO or H.NG LED indicator provides a visual display of test results based on a preset limit. Also, a buzzer can be enabled to sound based upon the same preset limits.

Start-up

The 1867 instrument can be operated from a power source between 95 and 250 VAC at a power line frequency of 48 to 62 Hz. The standard 1867 unit is shipped from QuadTech with a 0.315A fuse for AC 100V to 120V operation. To change the fuse refer to paragraph 1.4.3.

Connect the instrument AC power cord to the source of proper voltage.

Press the [POWER] button on the front panel to apply power. To switch power off press the [POWER] button again or if measurements are to be made proceed with Setting Limits below. Note that if measurements are to be made, the 1867 unit should warm up for at least 30 minutes.

Zeroing

The 1867 unit should be zeroed prior to making any measurements. To zero the 1867 unit, turn the [POWER] ON with no device connected. Set Multiplier dial to your specification resistance range. Set Test Voltage dial(s) to your specification test voltage. Place Discharge-Charge-Measure switch in MEASURE position. Adjust the Set ∞ knob so that the needle points to ∞ at the far right of the analog meter.

Setting Limits

Before measuring, set the following parameters :

Place toggle switch to LO LIM. Using a flat head screwdriver, turn the screw above LO LIM. to the low limit of your test specification.

Place toggle switch to HI LIM. Using a flat head screwdriver, turn the screw above HI LIM. to the high limit of your test specification..

Place toggle switch back to NORM before making any measurements.

Manual Measurement Mode

In manual measurement mode each phase of a test cycle, charge, measure and discharge is initiated manually at the users discretion. Refer to paragraph 3.3.3 for discussion on discharge time.

1. Turn [POWER] ON.
2. Zero the 1867 instrument.
3. Set Low Limit and High Limit according to your test specification.
4. Make sure the Discharge-Charge-Measure (D-C-M) toggle switch is set to DISCHARGE.
5. Connect the device under test (DUT) to the 1867 test leads or other test fixture.
6. Select Test Voltage.
7. Select Multiplier setting.
8. Switch the D-C-M toggle switch from DISCHARGE to CHARGE. Dwell time according to your test specification
9. Switch the D-C-M toggle switch from CHARGE to MEASURE.
10. Record the measured reading from analog meter.
11. Adjust the Multiplier setting if necessary.
12. Switch the D-C-M toggle switch to DISCHARGE.
13. Remove the DUT once it has had an adequate discharge time.

Section 1: Introduction

WARNING

High Voltage is present at the measurement terminals of the 1867 anytime the **Caution High Voltage LED** is **ON**.

While the current from the instrument is limited to a value that is not dangerous under most conditions, the energy stored in a capacitor connected to the terminals may be lethal. Always make sure the **Caution High Voltage LED** is **OFF** when connecting or disconnecting the device under test (DUT).

1.1 Unpacking and Inspection

Inspect the shipping carton before opening. If damaged contact the carrier agent immediately. Inspect the 1867 instrument for any damage. If the instrument appears damaged or fails to meet specifications notify QuadTech (refer to instruction manual front cover) or its local representative. Retain the shipping carton and packing material for future use such as returning for recalibration or service.

1.2 Product Overview

The 1867 IR Tester is a general purpose high voltage instrument for high resistance measurements on insulating materials and components. It is designed for easy, accurate and direct readings of high resistance typically found in synthetic resins, porcelains, insulating oils, plastics and other similar materials. It is also used for measurements on capacitors, transformers, switches, cables and connectors. The 1867 unit provides a direct readout of resistance from 50k Ω to 200T Ω . The voltage applied to the unknown is adjustable from 10 volts to 1090 volts.

The 1867 instrument includes an analog meter display. The test cycle of discharge charge and measure is operated by a toggle switch. L.NG (Low No Good), GO (Good) and H.NG (High No Good) LED indicators provide the operator with a visual indication based on a preset resistance limit. The unit also contains a buzzer that will give the operator an audio indication based on a preset limit.

Included as a safety feature is the front panel “**Caution High Voltage**” indicator which is ON when voltage is applied to the test terminals (CHARGE or MEASURE selected), thus permitting connections to be made safely.

The unit is supplied with front panel input connections with Guard and Ground terminals to permit measurements of grounded or ungrounded devices.

1.3 Controls and Indicators

1.3.1 Front Panel Controls and Indicators

Figure 1-1 illustrates the controls and indicators on the front panel of the 1867 megohmmeter instrument. Table 1-1 identifies them with description and function.

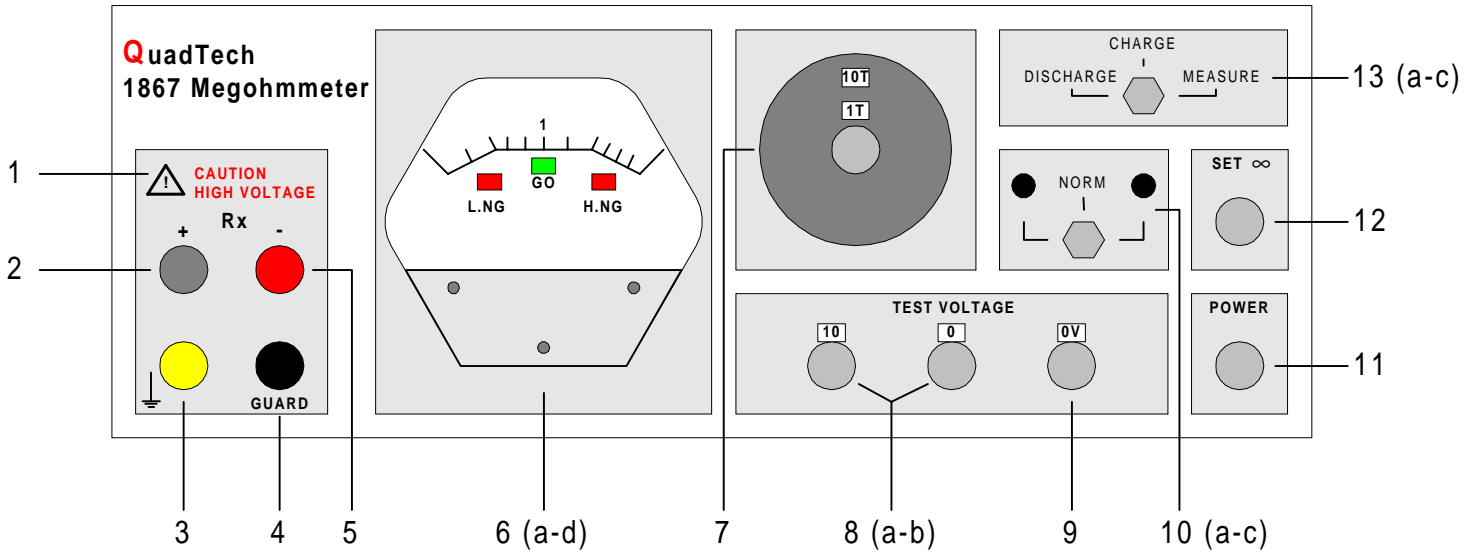

Figure 1-1: 1867 Front Panel Controls and Indicators

Table 1-1: 1867 Front Panel Controls and Indicators

Reference Number Fig. 1-1	Name	Type	Function
1	CAUTION HIGH VOLTAGE	Red LED	When lit indicates High Voltage is present at Output Terminals.
2	Rx +	Silver BNC connector	Sense (Low) Voltage connection to DUT
3	GROUND	Yellow Binding Post	Ground reference for all tests
4	GUARD	Black Binding Post	Connector for 3-Terminal Guarded measurements
5	Rx -	Red Sheathed Banana Plug	HV connection to DUT
6	Meter	4" Analog meter	Indicates the value to be multiplied by the multiplier switch
6a	L.NG	Red LED	Indicates Low Reading
6b	GO	Green LED	Indicates Good Reading
6c	H.NG	Red LED	Indicates High Reading
6d	Meter Adjust	Grey plastic flat head screw	Analog meter needle adjust
7	Multiplier	8 position rotary switch	Select resistance range
8a	Test Voltage	1, 10-position rotary switch	Select Test Voltage (100's value)
8b	Test Voltage	1, 10-position rotary switch	Select Test Voltage (1000's value)
9	Test Voltage	1, 2-position rotary switch	Select voltage range V or 0V where: V = Output V: 10-109V 0V = Output V: 100-1090V
10	Limit Switch	3-position toggle switch	Adjust Low & High test limits
10a	LO LIM.	Left toggle position Recessed flat head screw	Set Low Limit for L.NG judgement
10b	NORM	Mid-position of toggle switch	No adjustment
10c	HI LIM.	Right toggle position Recessed flat head screw	Set High Limit for H.NG judgement
11	POWER	Grey push button switch	Applies AC power to 1867 unit: 0 = OFF, 1 = ON
12	SET ∞	Grey rotary switch	Adjust the high end of meter scale to compensate for offset voltage in voltmeter
13	D-C-M	3-position toggle switch	Select Test Mode
13a	DISCHARGE	Left toggle position	No HV at Test Terminals: Off
13b	CHARGE	Mid toggle position	HV at Test Terminals: Dwell Time
13c	MEASURE	Right toggle position	HV at Test Terminals: Measure

1.3.2 Rear Panel Controls and Indicators

Figure 1-2 illustrates the controls and connectors on the rear panel of the 1867 instrument. Table 1-2 identifies them with description and function.

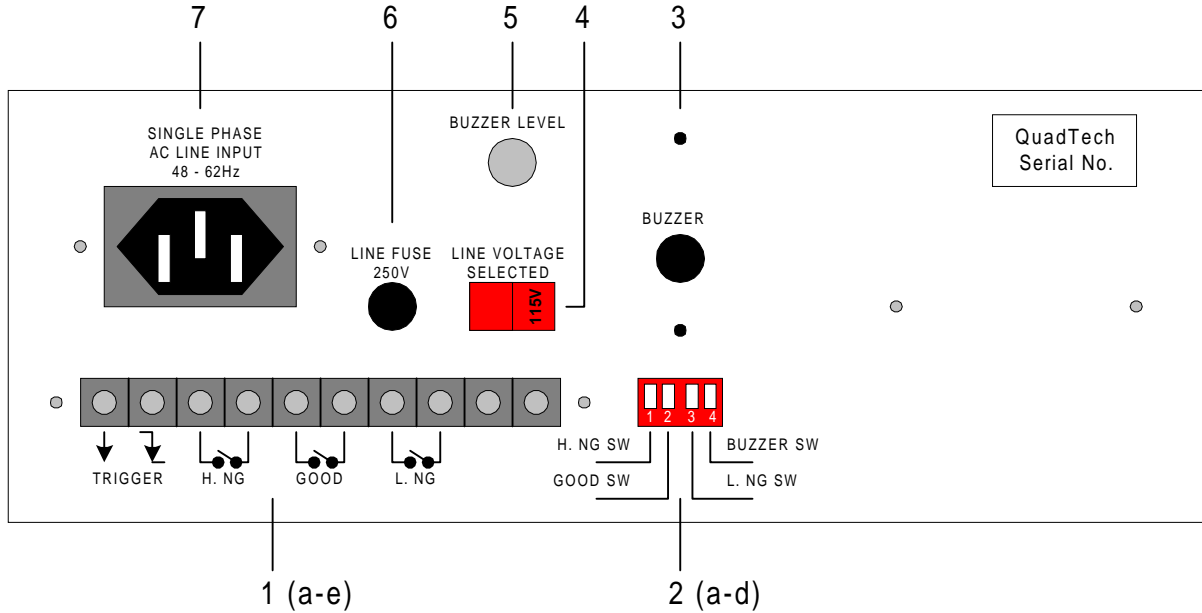

Figure 1-2: 1867 Rear Panel Controls and Connectors

Table 1-2: 1867 Rear Panel Controls and Connectors

Reference Number Figure 1-2	Name	Type	Function
1	REMOTE I/O	Black 10 Screw Strip	Connection for remote operation
1a	TRIGGER	1 ST set of 2 screws	Trigger Input to activate outputs
1b	H.NG	2 ND set of 2 screws	H.NG switch output
1c	GOOD	3 RD set of 2 screws	GOOD switch output
1d	L.NG	4 TH set of 2 screws	L.NG switch output
2	DIP ON	Red 4-Position DIP Switch	Select Mode in which buzzer sounds
2a	H.NG SW	Position 1	Enable H.NG
2b	GOOD SW	Position 2	Enable GO
2c	L.NG SW	Position 3	Enable L.NG
2d	BUZZER SW	Position 4	Enable buzzer
3	BUZZER	Hole	Emit buzzer sound
4	LINE VOLTAGE SELECTED	Red 2-Position Slide Switch	To select 110V or 220V
5	BUZZER LEVEL	Silver Rotary Switch	To control buzzer volume
6	LINE FUSE 250V	Black Screw Cap Fuse	0.315A 250V fuse for 115V operation 0.160A 250V fuse for 230V operation
7	AC LINE INPUT	Black 3-prong receptacle	3-wire connection for AC power source

1.4 Installation

1.4.1 Dimensions

The instrument is supplied in a bench configuration (a cabinet with resilient feet for placement on a table). A bail is provided under the front edge so that the instrument can be tilted back for convenient operator viewing.

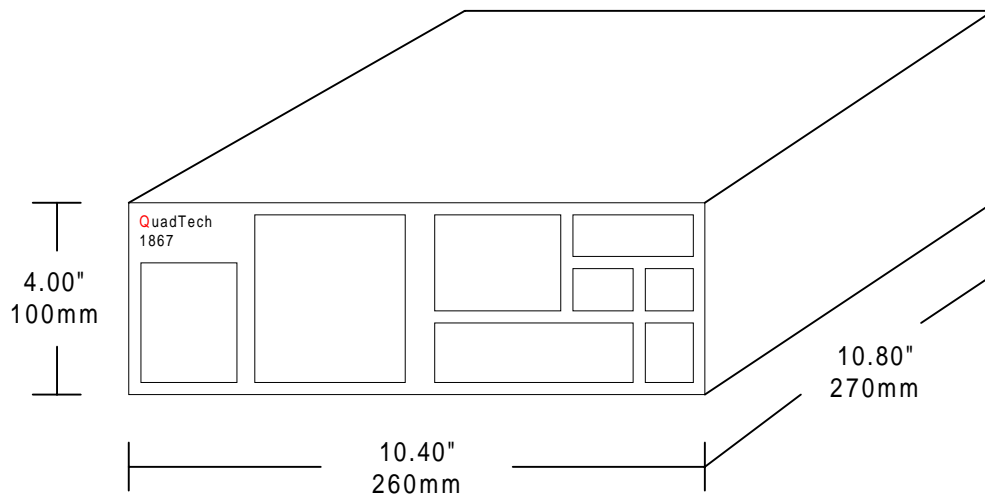



Figure 1-3: 1867 Instrument Dimensions

1.4.2 Instrument Positioning

The 1867 instrument contains a 4" analog meter with a plastic cover for convenient viewing. The optimum angle for viewing is slightly down and about 10 degrees either side of center. For bench operation the front bail should always be used to angle the instrument up. In bench or rack mount applications the instrument should be positioned with consideration for ample air flow around the rear panel. An open space of at least 3 inches (75 mm) is recommended behind the rear panel.

1.4.3 Power Requirements

 The 1867 Megohmmeter/IR Tester can be operated from a power source between 95 and 250VAC at a power line frequency of 48 to 62Hz. Power connection to the rear panel is through a standard AC inlet module. There is a separate screwcap power fuse. Before connecting the 3-wire power cord between the unit and AC power the fuse should be in accordance with the power source, 0.315A fuse for the standard 115V source or 0.160A fuse for 230V source. Always use an outlet which has a properly connected protection ground. **The standard 1867 is shipped from QuadTech with the 0.315A fuse in place (for 115V). The instrument can be damaged if the wrong fuse is installed.** To change the fuse refer to Figure 1-4 and use the procedure on the next page.

PROCEDURE FOR CHANGING A FUSE

WARNING
MAKE SURE THE UNIT HAS BEEN DISCONNECTED FROM ITS AC POWER SOURCE FOR AT LEAST 5 MINUTES BEFORE PROCEEDING.

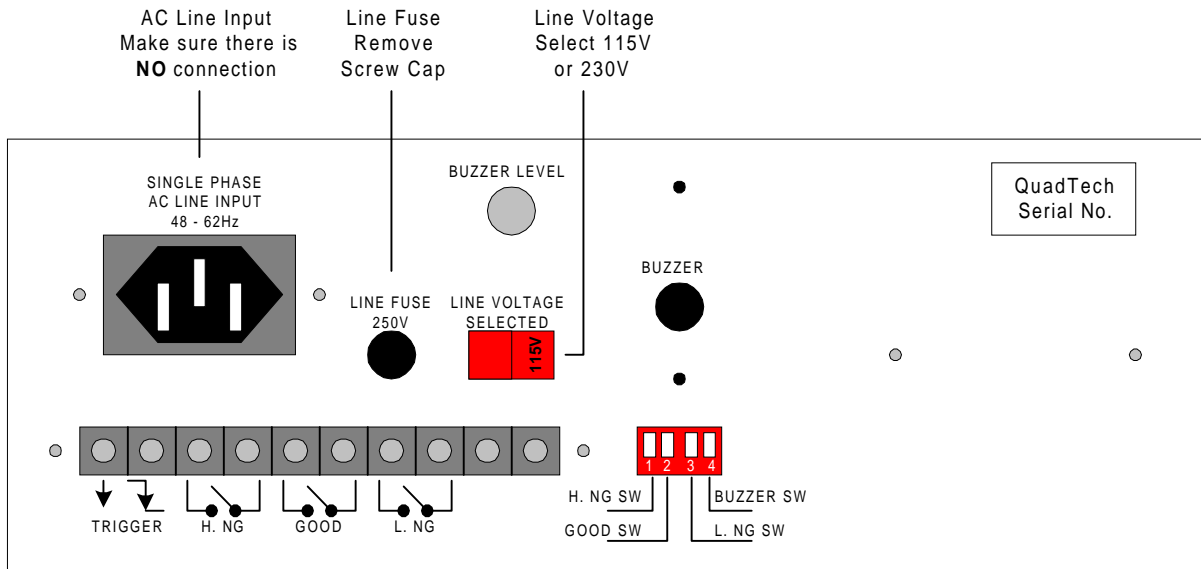

Figure 1-4: 1867 Fuse & Voltage Selector Location

- Make sure the power switch is OFF and the power cord is disconnected from the unit and the AC power source.
- Inspect if the fuse is functional by measuring resistance ($< 15\Omega$) with an ohmmeter.
- Using a flat head screwdriver, turn the screwcap about 60° counterclockwise. The screwcap should protrude about 3.0 cm from the socket.
- Remove screwcap. Replace with new fuse.
- Replace screw cap in 1867 unit and turn the screwcap about 60° clockwise.
- Switch Voltage Selector to proper power source: 115V or 230V

1.4.4 Safety Inspection



Before operating the instrument inspect the power inlet module on the rear of the 1867 unit to ensure that the **properly rated fuse is in place**, otherwise damage to the unit is possible. Refer to paragraph 1.4.3.

The 1867 instrument is shipped with a standard U.S. power cord, QuadTech PN 4200-0300 (with Belden SPH-386 socket or equivalent, and 3 wire plug conforming to IEC 320). Make sure the instrument is only used with these cables (or other approved international cord set) which ensures the instrument is provided with **connection to protective earth ground**.

The surrounding environment should be **free from excessive dust** to prevent contamination of electronic circuits. The surrounding environment should also be free from excessive vibration. Do not expose the 1867 instrument to direct sunlight, extreme temperature or humidity variations, or corrosive chemicals.

WARNING

If this instrument is used in a manner not specified in this manual, protection to the operator and equipment may be impaired.

Section 2: Operation

2.1 Terms and Conventions

Table 2-1: Measurement Unit Prefixes

<u>Multiple</u>	<u>Scientific</u>	<u>Engineering</u>	<u>Symbol</u>
1000000000000000	10 ¹⁵	Peta	P
1000000000000	10 ¹²	Tera	T
1000000000	10 ⁹	Giga	G
1000000	10 ⁶	Mega	M
1000	10 ³	Kilo	k
.001	10 ⁻³	milli	m
.000001	10 ⁻⁶	micro	u
.000000001	10 ⁻⁹	nano	n
.000000000001	10 ⁻¹²	pico	p
.00000000000001	10 ⁻¹⁵	femto	f

ARcing: Sparking or ‘flashing over’ caused by a breakdown of electrical insulation.

Charging Current: An insulated product exhibits the basic characteristics of a capacitor. Application of a voltage across the insulation causes a current to flow as the capacitor charges. This current instantaneously rises to a high value as voltage is applied then exponentially decays to zero as the DUT becomes fully charged. Charging current decays to zero much faster than dielectric absorption.

Current:

AC: Alternating Current. An electric current that has one polarity during part of the cycle and the opposing polarity during the other part of the cycle. Residential electricity is AC.

DC: Direct Current. Non-reversing polarity. The movement of charge is in one direction. Used to describe both current and voltage. Batteries supply direct current (DC).

Dielectric Absorption: The physical phenomenon in which insulation appears to absorb and retain an electrical charge slowly over time. Apply a voltage to a capacitor for an extended period of time, then quickly discharge it to zero voltage. Leave the capacitor open circuited for a period of time then connect a voltmeter to it and measure the residual voltage. The residual voltage is caused by the dielectric absorption of the capacitor.

Dielectric Strength:	The ratio between the voltage at which breakdown of the insulating material occurs and the distance between the two points subject to the applied voltage.
Dielectric Withstand Test:	This is the most common electrical safety test performed. A high voltage (either AC or DC) is applied to determine if a breakdown will occur in the insulation of the DUT. Dielectric Withstand is also referred to as a hipot (high potential) test.
Discharge:	The act of draining off an electrical charge to ground. Devices that retain charge should be discharged after an IR test or a DC hipot test.
DUT:	Device Under Test. The product being tested.
Frequency:	The rate at which current or voltage reverses polarity and then back again completing a full cycle, measured in Hertz (Hz) or cycles/second. AC Line Frequency = 50/60 Hz.
Ground:	The base reference from which voltages are measured, nominally the same potential as the earth. Also the side of a circuit that is at the same potential as the base reference.
Insulation Resistance:	Measures the total resistance between any two points separated by electrical insulation. The IR test determines how effective the dielectric (insulation) is in resisting the flow of electrical current.
Interface:	
IEEE-488:	General Purpose Interface Bus (GPIB). An industry standard definition of a Parallel bus connection for the purpose of communicating data between devices.
RS232:	An industry standard definition for a Serial line communication link or port.
Scanner:	A electronic device designed to switch or matrix signals.
Leakage Current:	The residual flow of current that flows through the insulation after a high voltage has been applied for a period of time. The leakage current is equal to the applied voltage divided by the insulation resistance. Leakage current is the main measured value for AC hipot and DC hipot.

Limits:

High Limit:	The high limit is the upper value for a test to be considered a pass. If the measured value is higher than the high limit the test is considered a fail. In hipot, leakage current and ground bond test modes a high limit is required.
Low Limit:	The low limit is the lower value for a test to be considered a pass. If the measured value is lower than the low limit the test is considered a fail. In insulation resistance test mode a low limit is required.
Mode:	The test which is to be performed such as AC Hipot (WAC), DC Hipot (WDC), Insulation Resistance (IR), Ground Bond (GR) or Leakage Current (LC).
RAMPing:	The gradual increase or decrease of voltage or current over a period of time (step).
Step:	The Guardian 6100/6200 can perform up to 10 tests in a sequence. The step number indicates in which order the tests will be performed. For example if step 1 is a ground bond test, step 2 an AC hipot and step 3 an insulation resistance measurement then when a test is started the Guardian 6100/6200 will perform a ground bond test followed by an AC hipot then an insulation resistance measurement.

2.2 Startup

Check to make sure the line voltage indicator on the rear panel AC inlet module agrees with the AC power source available, if not refer to paragraph 1.4.3.

Connect the instrument power cord to the source of proper voltage. **The instrument is to be used only with three wire grounded outlets.**

WARNING

A Caution High Voltage LED indicator lights when Charge or Measure is selected (i.e. there is High Voltage present at the output terminals).

Power is applied to the 1867 by pressing the [POWER] button on the front panel. The 1867 instrument should warm up for at least 30 minutes prior to testing.

2.3 Zeroing

The 1867 unit should be zeroed prior to making any measurements. To zero the 1867 unit, turn the [POWER] ON with no device connected. Set Multiplier dial to your specification resistance range. Set Test Voltage dial(s) to your specification test voltage. Place Discharge-Charge-Measure switch in MEASURE position. Adjust the Set ∞ knob so that the needle points to ∞ at the far right of the analog meter.

2.4 Setting Limits

The general operation of the LO and HI limits are if the measured resistance is between the set LO and HI limits then the “GO” LED is lit. If the measured resistance is lower than the set LO limit, then the “L.NG” LED is lit. If the measured resistance is higher than the set HI limit, then the “H.NG” LED is lit.

Before making measurements, the limits should be set according to your test specification.

- Switch toggle switch to [LO LIM.]. Using a flat head screwdriver, turn the screw above LO LIM. to your low limit of your test specification.
- Switch toggle switch to [HI LIM.]. Using a flat head screwdriver, turn the screw above HI LIM. to your High Limit of your test specification.
- Return toggle switch to [NORM] prior to making a measurement.

2.5 D-C-M Toggle Switch

The DISCHARGE-CHARGE-MEASURE toggle switch (abbreviated D-C-M) located on the top right side of the front panel is used to select the Test Mode. In [DISCHARGE] position the High Voltage has been cut off from the DUT. In [CHARGE] position HV is applied to the DUT allowing for a manual dwell time. In [MEASURE] position the HV is applied to the DUT and measurement values can be manually recorded from the analog meter. When [CHARGE] or [MEASURE] is selected the **Caution High Voltage** LED is **ON** indicating that HV is present at the output terminals. Always place the D-C-M switch in [DISCHARGE] position before connecting or disconnecting the DUT.

2.6 Resistance Ranges

The 1867 instrument is capable of measuring the resistance ranges listed in Table 2-2. Use the [Multiplier] dial to select the proper resistance range for the test being performed.

Table 2-2: 1867 Resistance Ranges

Resistor Range	Standard Resistor Value	Resistance Accuracy	Inner Display Multiplier Dial	Outer Display Multiplier Dial
1	100Ω	±2%(meter reading + 1cnt)	1M	100k
2	1kΩ	±2%(meter reading + 1cnt)	10M	1M
3	10kΩ	±2%(meter reading + 1cnt)	100M	10M
4	100kΩ	±2%(meter reading + 1cnt)	1G	100M
5	1MΩ	±2%(meter reading + 1cnt)	10G	1G
6	10MΩ	±2%(meter reading + 1cnt)	100G	10G
7	100MΩ	±5%(meter reading + 1cnt)	1T	100G
8	1GΩ	±10%(meter reading + 1cnt)	10T	1T

2.7 Voltage Selector

A red 2-position Voltage Selector switch is located on the rear panel of the 1867 instrument as shown in Figure 1-2. Select 115V operation or 230V operation according to the AC power source available.

2.8 Test Voltage

Three gray Test Voltage knobs are located on the front panel of the 1867 instrument as shown in Figure 1-1. Make sure the [D-C-M] switch is in the [DISCHARGE] position. Make sure there is no DUT connected to the output terminals. Rotate the Test Voltage knobs to select the applied voltage. The right most knob is used to select [V] or [0V]. Select [V] for a Test Voltage between 10V and 109V. Select [0V] for a Test Voltage between 100V and 1090V. Use the center and left Test Voltage knobs to select applied voltage value.

2.9 Buzzer DIP Switch

Figure 2-1 illustrates the red 4-position DIP switch on the rear panel of the 1867 instrument. This DIP switch permits the operator the option of setting the buzzer to sound in three modes: H.NG, GOOD or L.NG. The DIP switch is ON when it is in the DOWN position. Switch #4 is the switch that enables the buzzer to sound. Switch #4 must be in the DOWN position for the buzzer to sound. Switch #1 is labeled H.NG. When switch #1 and switch #4 are ON the buzzer will sound when the test result is above the High Limit (as set in ¶ 2.4). Switch #2 is labeled GOOD. When switch #2 and switch #4 are ON the buzzer will sound when the test result is within the High and Low limits (as set in ¶ 2.4). Switch #3 is labeled L.NG. When switch #3 and switch #4 are ON the buzzer will sound when the test result is below the Low Limit (as set in ¶ 2.4).

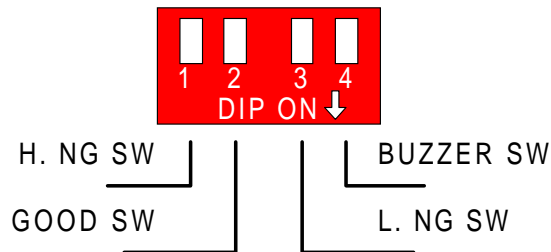

Figure 2-1: Buzzer DIP Switch

2.10 Connection to Device under Test (DUT)

Before connecting or disconnecting the DUT, make sure the [D-C-M] switch is in the [DISCHARGE] position. A shielded lead set is provided with the 1867 instrument: QuadTech part number 1867-01. The 1867 is supplied with a quieting resistor in the Rx- lead. To ensure proper operation of the unit, this resistor should **not** be removed from the lead. How the connection to the DUT is made depends on the device being measured, if it is a grounded, ungrounded or guarded device. Figures 2-2 through 2-5 illustrate possible connections to the DUT.

CAUTION

Do NOT ground the Rx+ (positive unknown) terminal, invalid measurements will result.

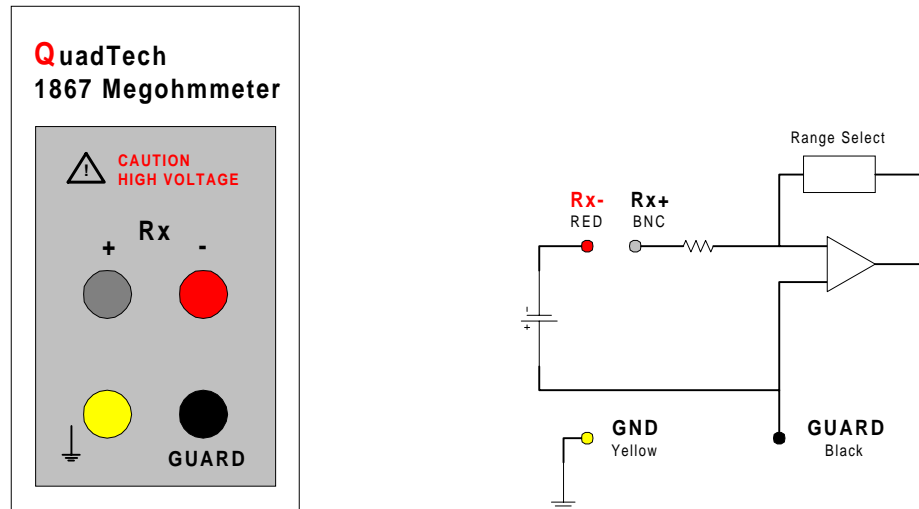

Figure 2-2: 1867 Output Terminals and Block Diagram

2.10.1 Two-Wire Ungrounded Connection

The 2-wire UNGROUNDED connection is the recommended set-up for testing ungrounded components. This is the most common configuration for testing two (2) terminal devices such as capacitors, resistors and other discrete components. In the normal measurement configuration (the shorting link is between GND and GUARD), the **Rx+** lead (Sense voltage connection) is virtual ground in this case and the **Rx-** lead (High voltage connection) is negative.

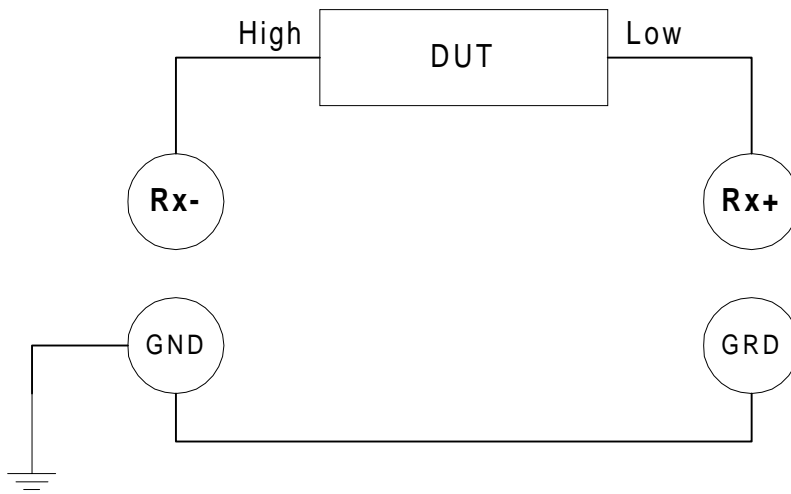
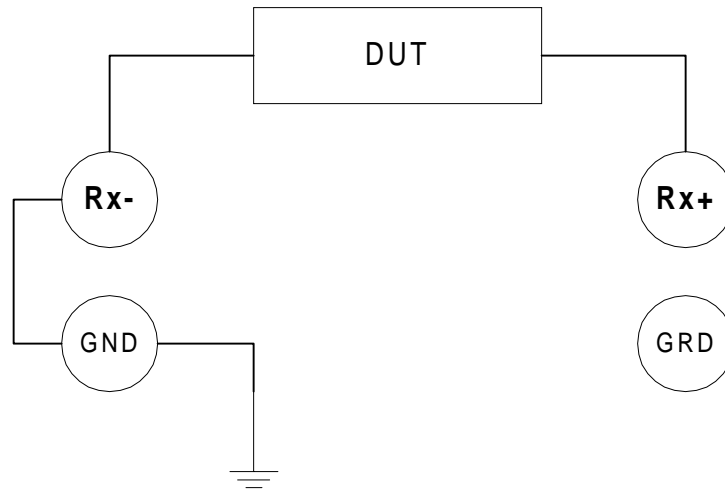

Figure 2-3: Two Wire UNGROUNDED Connection

2.10.2 Two-Wire Grounded Connection

The 2-wire GROUNDED measurement is a common type of connection to be used on the 1867 instrument. This is the recommended connection on grounded components or components that are some physical distance from the input terminals to the unit. A grounded component is one in which one of its connections goes to an earth ground, whereas on an ungrounded component neither connection goes to earth ground. A component being measured with a lead set is considered to be a physical distance away from the terminals and thus the two-wire grounded connection is often recommended. Measurement of insulation resistance of a cable in a water bath is a typical application of a 2-wire grounded connection. In this configuration note that Rx+ and GUARD are hot positive.



Rx- and Rx+ connected to DUT
Rx- connected to GND

Figure 2-4: Two-Wire GROUNDED Connection

2.10.3 Three-Wire Guarded Connection (Grounded or Ungrounded)

A 3-wire GUARDED connection is necessary to measure resistance between two points in the presence of resistance from each of these points to a third point. Refer to paragraph 3.6 for a discussion of guarded measurements. The guarded measurement may require different grounding techniques depending on the expected impedance of the DUT. The **DUT GROUNDED** configuration is recommended for high accuracy measurements as well as measurements with a large amount of noise.

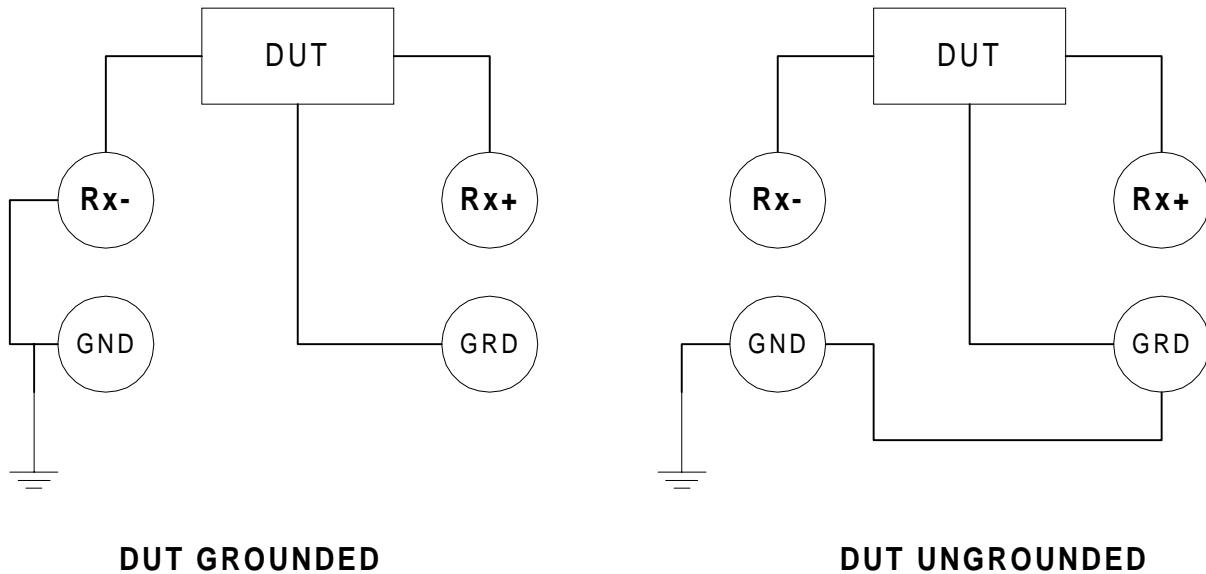

Rx- and Rx+ connected to DUT
GUARD to DUT Guard Point
Rx- shorted to GND
OR
GUARD shorted to GND

Figure 2-5: 3-Wire GUARDED Connection (Grounded or Ungrounded)

2.11 Measurement Procedure

2.11.1 Manual Measurement Mode

The 1867 instrument makes measurements in manual mode. In the manual mode the test cycle timing is totally at the users discretion where each of the three phases, charge, measure or discharge is initiated directly by the user. It is recommended that the DUT be charged (dwell time) for at least 1-2 minutes prior to switching the toggle switch to measure. The actual charge and discharge time will be governed by the amount of capacitance associated with the DUT. After recording measurement switch toggle switch back to discharge and wait 1-2 minutes for charge to leave DUT before disconnecting it.

When the 1867 is powered up it is ready to begin measuring after a warm up time of at least 30 minutes.

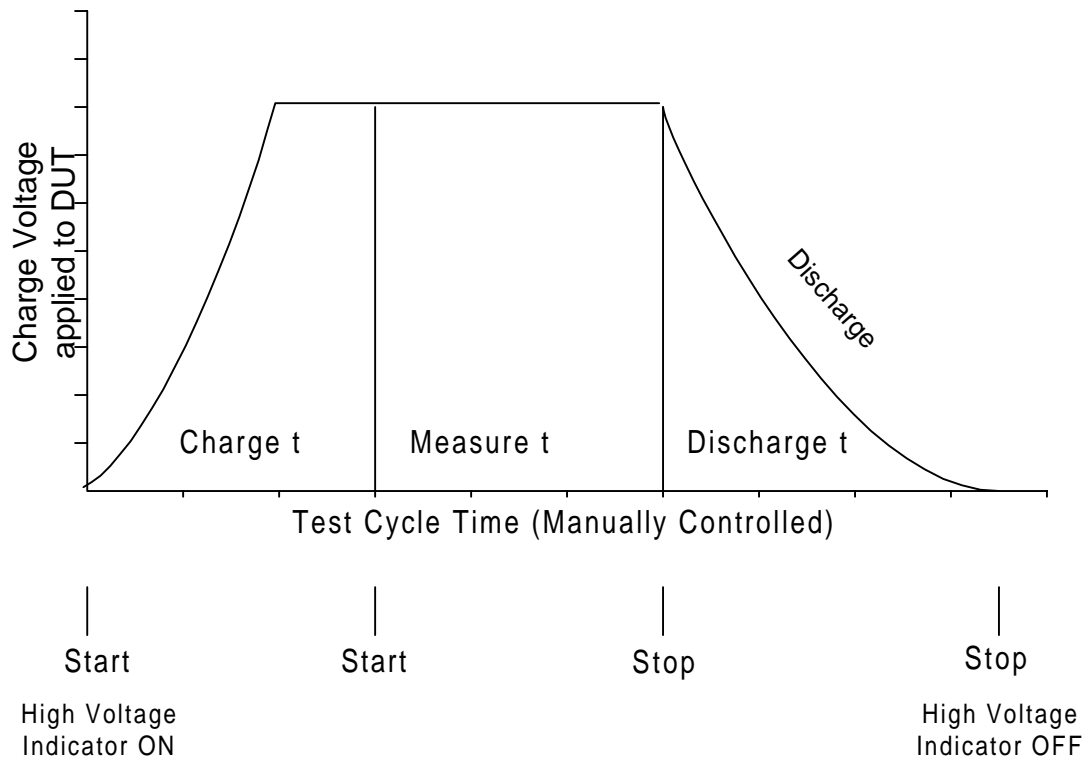

Figure 2-6: 1867 Manual Measurement Mode

2.12 Remote I/O

Figure 2-7 illustrates the remote control connector located on the rear panel of the 1867 megohmmeter. The connector is a standard 10-screw terminal strip. There are three (3) output connections: Fail High (H.NG), Fail Low (L.NG) and Pass (GOOD). The outputs are normally open relays.

When one of the outputs is true the appropriate relay will be closed. An Example : the megohmmeter indicates a PASS on the front panel (GO LED is lit), therefore on the rear panel the PASS relay will be closed and the two (2) FAIL relays (L.NG & H.NG) will be open.

The output relays are only active when a connection is made between the two TRIGGER contacts. This connection can be made using a jumper wire or using a PLC (Programmable Logic Controller) or other logic to control when the output relays are active. The output relays are rated at 0.6A 125VAC and 0.6A 110VDC.

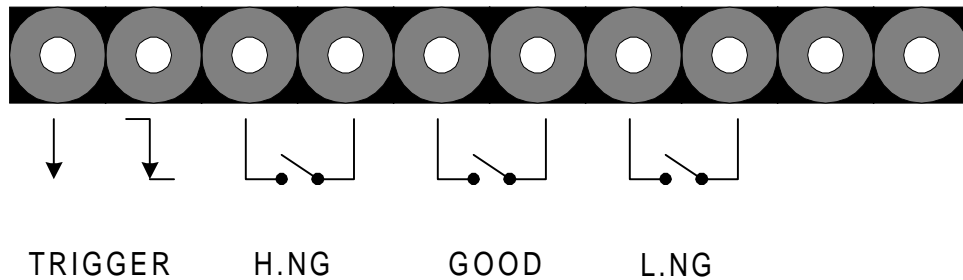

Figure 2-7: 1867 Remote I/O Strip

Section 3: Applications

3.1 Insulation Resistance Testing

Insulation resistance of materials is one of several parameters that may indicate the condition of insulation. An insulation test is to measure the resistance offered by the insulating members of a component part to an impressed direct voltage tending to produce a leakage of current through or on the surface of these members. There are times when knowledge of insulation resistance can be very important, for example; when resistance is high it may be the limiting factor in design of a high-impedance circuit, when resistance is low it can disturb the operation of circuits intended to be isolated. Insulation resistance measurements should **not** be considered the equivalent of a voltage breakdown test. Material with high insulation resistance could possess a mechanical fault that might fail during a voltage test and conversely material with low insulation resistance might not breakdown during a voltage test.

Factors that affect insulation resistance measurements include such things as temperature, humidity, previous conditioning, test voltage, charging current and duration of the test voltage (electrification time). It is characteristic of certain components (for example, capacitors or capacitive components or materials) for the current to fall from an instantaneous high value to a steady lower value, consequently the measured insulation resistance will increase from an appreciable time as test voltage is applied. Because of this it may take minutes to approach maximum insulation resistance readings, thus specifications usually require that readings be taken after a specified time, again electrification time. A routine test that has been widely adopted for insulation testing calls for the measurement of the apparent leakage resistance after a test voltage has been applied for 1 to 2 minutes.

Table 3-1: Standard Resistor Values (Rs)

Inner Display Multiplier Dial	Outer Display Multiplier Dial	Resistor Range	Standard Resistor Value
1M	100k	1	100Ω
10M	1M	2	1kΩ
100M	10M	3	10kΩ
1G	100M	4	100kΩ
10G	1G	5	1MΩ
100G	10G	6	10MΩ
1T	100G	7	100MΩ
10T	1T	8	1GΩ

3.2 Test Sample Resistivity Measurements

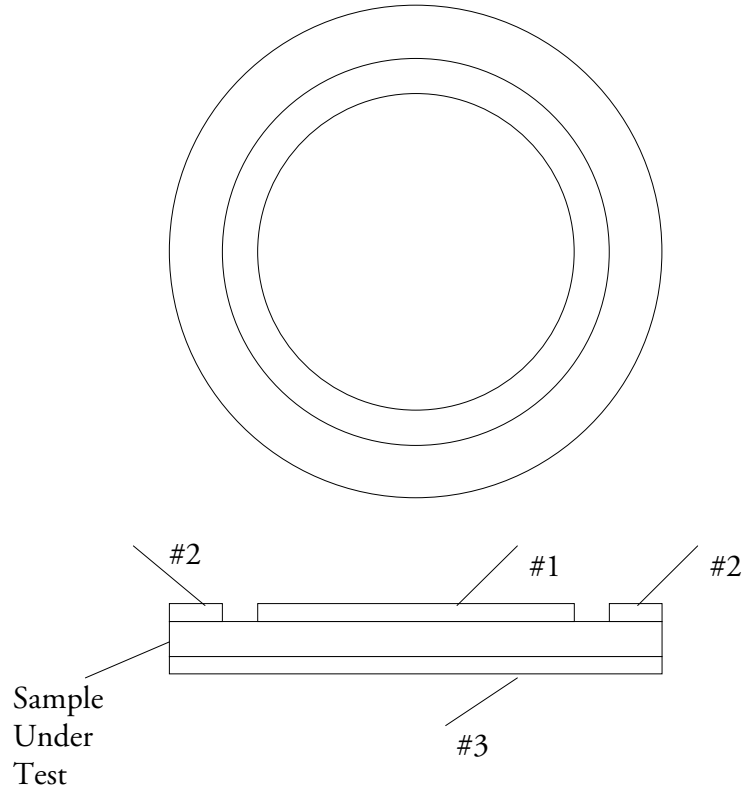

Figure 3-1: Test Sample Cell

The 1867 can be used for measuring surface and volume resistivity of test samples as described by ASTM Standard D 257. The most common electrode arrangement is shown in Figure 3-1.

Table 3-2: Sample Resistivity Test Connections

Resistivity Test	Terminal 1 Connection	Terminal 2 Connection	Terminal 3 Connection	Formula
Surface Resistivity	Rx-	Rx+	Guard	$P_s = \frac{P}{g} R_s$
Volume Resistivity	Rx-	Guard	Rx+	$P_v = \frac{A}{t} R_v$

- A= effective area of the measuring electrode
- P = effective parameter of the measuring electrode
- g = dimension of space between electrode (Terminal) 2 and electrode (Terminal) 1
- t = average thickness of the specimen
- Rs = measured surface resistance in ohms (Ω)
- Rv = measured volume resistance in ohms (Ω)

Refer to ASTM D-257, Table 2 for Area (A) Formulas

3.3 Capacitor Insulation Resistance

The insulation resistance measurements of capacitors is different from that of resistors by the fact that some consideration must be given to the charge and discharge currents.

Consideration should also be given to high value, low leakage capacitive devices relative to DC resistance measurements. Inherent to some degree in all high resistance measurement instrumentation is the inability to provide stable leakage measurements on high value capacitors. This is due to the fact that a capacitive element is very ac sensitive and the dc voltage applied to the device always contains a small percentage of low frequency noise ripple. Measurements on pure resistive elements will tolerate a high degree of ripple due to the voltage ratio measurements whereas a capacitor easily passes the noise ripple. When this is amplified by the current amplifier of the measuring instrument results can fluctuate and vary widely. To eliminate this in the 1867 unit, the test lead contains a resistor placed in series with the unknown. This added resistance has negligible effect on the dc measurement since its value is very small compared to the leakage resistance of the unknown however it increases the ac input resistance to the current amplifier, reducing the ac gain and thus minimizing the wide fluctuations. This added resistance will have an effect on the charge time constant and is discussed briefly in paragraph 3.3.1.

WARNING
Capacitors being measured may be charged and contain lethal energy.
Always make sure the Caution High Voltage LED is NOT on when connecting or disconnecting the capacitor under test.

Example: DUT = 1 μ F capacitor, 2Wire UNGRD Connection (Figure 2-2)

$$\text{Charging Time Constant} = \frac{(\text{Capacitor Value}) (\text{Effective Source Impedance of Supply})}{(C_{\text{value}}) (R_{\text{supply}})}$$

Test Voltage E (volts)	Supply Resistance R _{supply} (ohms)	Capacitor Value C _{value} (μ F)	Charging Time Constant T _{charge} (seconds)
100V	20K Ω	1 μ F	0.020 seconds
500V	100K Ω	1 μ F	0.100 seconds

The time necessary for fully charging a capacitor is dependent on its type and the leakage current that is to be measured. A capacitor with no dielectric absorption will have a charging current that decreases by a factor of 2.72 for every time constant it is left in Charge. Example : a 1 μ F capacitor with a leakage resistance of 10¹⁰ Ω measured at 500V would have less than 1% error due to the charging current, if measured after 17 time constants or 1.7 seconds.

3.3.1 Charge Time Constant

The time constant for charging a capacitor in the charge phase is determined by the value of the capacitor times the effective source impedance of the supply. The supply resistance is approximately,

$$R_o = \frac{E}{I_{\max}} \Omega = \frac{E}{0.005 \text{ A}} \Omega = \frac{E}{5} \text{ k}\Omega$$

where E is the user specified test voltage in volts and I max is the current limit of the 1867, which is approximately 5mA. Therefore, the time constant is

$$T = R_o C_x = \frac{E C_x}{5000} \text{ seconds}$$

where Cx is in uF. As an example, for a 500V test voltage Ro is approximately 250kΩ so that the time constant for charging of a 1 uF capacitor is 0.25 seconds.

When a resistance adaptor is used the time constant will be increased. In the example above if the 100kΩ or 1MΩ adaptor is placed in series with the effective source impedance of 250kΩ the charge time will be increased by a factor of 0.4 and 4 respectively.

3.3.2 Discharge Time

The Caution High Voltage LED is turned OFF after the user specified discharge time. If the discharge time is set to zero or a very short time a capacitor could remain with a charge after the indicator is extinguished. However, the discharge time is so short this is not a practical consideration except for capacitors greater than 10 uF or so.

Capacitors with high dielectric absorption can have a residual charge even after they are shunted and must be repeatedly shunted to completely discharge. Usually a "voltage recovery" of this type would be a very small percentage of the original applied voltage and generally not dangerous to the operator. This risk is further minimized by the fact that the 1867 circuitry remains in a discharge mode until the operator initiates another charge and measure cycle.

3.4 Resistance Measurements

The recommended test voltage is typically 100 V for fixed composition resistors, film resistors or wire wound resistors above 100kΩ. Refer to EIA (Electrical Industry Association) Standards. These resistors (values greater than 1000Ω) can easily be measured on the 1867 where the instrument basic accuracy of 2.0% is adequate. For single component resistors a two terminal connection, Rx+ and Rx- is recommended.

3.5 Measurement of Voltage Coefficient

The 1867 may be used to measure voltage coefficient which is defined as :

$$\frac{R_1 - R_2}{R_2 (V_1 - V_2)} \times 100\%$$

where $V_1 > V_2$

R1 is the resistance at V1, the higher voltage

R2 is the resistance at V2

For example, if $V_1 = 500 \text{ V}$ and $V_2 = 100 \text{ V}$,

$$\text{Voltage Coefficient} = \frac{R_{500\text{V}} - R_{100\text{V}}}{R_{100\text{V}} (400)} \times 100\%$$

$$= \frac{1}{4} \frac{\Delta R}{R_{100\text{V}}} \%$$

This voltage coefficient is usually negative.

Example: $R_1 = 0.929 \times 10^9 \Omega$ $V_1 = 500\text{V}$, $R_2 = 0.959 \times 10^9 \Omega$ $V_2 = 100\text{V}$

$$\text{Voltage Coefficient} = \frac{(0.929 \times 10^9 - 0.959 \times 10^9)}{(0.959 \times 10^9) (400)} \times 100\%$$

3.6 Guarded, 3-Terminal Measurements

In many cases it is necessary to measure the resistance between two points in the presence of resistance from each of these points to a third point. This third point can often be guarded to avoid error caused by the extraneous resistance. This can best be illustrated as shown in Figure 3-2 below. Here R_X is the quantity to be measured in the presence of R_A and R_B . If the junction of R_A and R_B is tied to guard, R_A is placed across the voltage source and has no effect if it is greater than 1.25 Mohms. As long as R_B is greater than R_S (standard range resistor) the error caused by R_B is minimized, thus if there is a choice its better to have the higher of the two stray resistances connected to R_B .

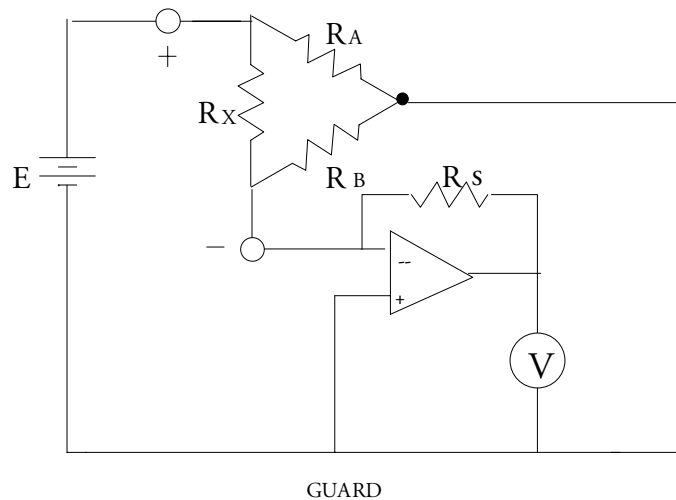

Figure 3-2: Guarded Measurement Configuration

The guard terminal can be used whether GUARD or the R_{X+} terminal is grounded, but it's important to note that if the R_{X+} terminal is grounded the GUARD terminal will be at a high negative voltage level. **When the GUARD terminal is connected to a true ground of a device, such as chassis, the Guard terminal must be grounded, not the R_{X+} terminal.**

Section 4: Service & Calibration

4.1 General

Our warranty (at the front of this manual) attests the quality of materials and workmanship in our products. If malfunction should be suspected, or other information be desired applications engineers are available for technical assistance. Application assistance is available in the U.S. by calling 978-461-2100 and asking for Applications Support. For support outside of the United States please contact your local QuadTech distributor.

4.2 Instrument Return

Before returning an instrument to QuadTech for service please call our **Customer Care Center (CCC)** at **800-253-1230** for return material authorization (RMA). It will be necessary to include a Purchase Order Number to insure expedient processing, although units found to be in warranty will be repaired at no-charge. For any questions on repair costs or shipment instructions please contact our CCC Department at the above number. To safeguard an instrument during storage and shipping please use packaging that is adequate to protect it from damage, i.e., equivalent to the original packaging and mark the box "Delicate Electronic Instrument". Return material should be sent freight prepaid, to:

QuadTech, Inc.
5 Clock Tower Place, 210 East
Maynard, MA 01754

Attention: RMA #

Shipments sent collect can not be accepted.

4.3 Calibration

Calibration of the 1867 Megohmmeter is recommended on an annual basis. If the unit is to be returned to QuadTech for factory calibration refer to paragraph 4.2 for instructions. **Using the procedure below the instrument can also be calibrated by a qualified service person if traceable calibration equipment and standards are available.**

4.3.1 Calibration Equipment

- 4 ½ digit voltmeter (Fluke 8842A Multimeter or equivalent) traceable to NIST
- 100k Ω , 0.1% ½ watt Standard Resistor traceable to NIST.
- 1T Ω , 3% 5 watt Standard Resistor traceable to NIST.

4.3.2 Calibration Procedure

4.3.2.1 Output Voltage Adjustment

1. Connect to RX- and GND on front panel.
2. Set test voltage dials to 5-0-0V.
3. Set D-C-M toggle switch to [CHARGE].
4. Adjust power supply VR1 (on bottom PCB) to read 500.0 ± 0.2 VDC.
5. Set test voltage dials to 5-0-V.
6. Adjust power supply VR2 (on bottom PCB) to read 50.0 ± 0.1 VDC.
7. Set D-C-M toggle switch to [DISCHARGE].

4.3.2.2 Offset Voltage Adjustment

1. Connect voltmeter to R18 (junction with U17 pin 6).
2. Adjust JP2 to read 0.0000 ± 0.0001 VDC.

4.3.2.3 Accuracy Adjustment

1. Connect voltmeter to R34 (junction with U16 pin 1) and GND.
2. Set test voltage dials to 5-0-0V.
3. Adjust VR1 (top PCB) to read 5.000 ± 0.001 VDC.
4. Set test voltage dials to 5-0-V.
5. Adjust VR6 (top PCB) to read 5.000 ± 0.001 VDC.
6. Connect voltmeter to JP5 Pin 2 and GND.
7. Set Range multiplier dial to 100K.
8. Adjust VR4 (top PCB) to read 1.000 ± 0.001 VDC.
9. Connect $100\text{k}\Omega$ standard to RX- and RX+.
10. Adjust Set ∞ knob to read $\infty \pm 1$ pointer width on front panel meter.
11. Set D-C-M toggle switch to [MEASURE].
12. Adjust VR5 (top PCB) to read exactly 1 on front panel meter.
13. Set D-C-M toggle switch to [DISCHARGE].
14. Connect $1\text{T}\Omega$ standard to RX- and RX+.
15. Set test voltage dials to 5-0-0V.
16. Set Range multiplier dial to 1T.
17. Adjust Set ∞ knob to read $\infty \pm 1$ pointer width on front panel meter.
18. Adjust VR2 (bottom PCB) to read exactly 1 on front panel meter.